

**POLICIES
AND
GUIDELINES**

for a

**“Safe Trailering”
Driver Education Program**

This is a FREE booklet.
No one is authorized to charge a fee for it,
or to use it to collect data.

You may download, display, print and reproduce this material in unaltered form only (retaining this notice) for your personal, noncommercial use, or use within your organization. All other rights are reserved.

Attribution notice for information from this publication must be given and should take the following form:

This booklet was developed by
U-Haul International, Inc., in cooperation with the
American Driver and Traffic Safety Education Association
(ADTSEA).

Additional copies of this booklet can be secured from
either **www.uhaul.com** or **www.adtsea.org**

Copyright © 2008 U-Haul International, Inc.



Contents

Foreword/Acknowledgments	iii
Developing a Trailering Program	iv
How To Use This Guide.....	v
Introduction	1
Section 1: Systems Concept.....	2
Section 1a: The Driver	3
Section 1b: The Tow Vehicle.....	5
Section 1c: Hitches.....	8
Section 1d: The Trailer	10
Section 2: Loading	19
Section 3: Operation of the Car-Trailer Combination	23
Appendix: On-Site Safe Trailering course	33

Foreword

The central purpose of this publication is to provide basic, practical trailering information and guidelines for beginning drivers and first-time trailer/towing customers. People who tow a trailer only occasionally would benefit from a review of the information contained in these guidelines.

- As concerns over fossil fuel have increased, people are turning to trailering as a low carbon footprint alternative. It is estimated that a cargo or travel trailer reduces the carbon footprint over a cargo truck or motor home by 30-50 percent.
- The trailering activities of North Americans have become increasingly broad each year and the need for trailering-safety education has increased accordingly.
- Trailers remain one of the most popular and cost-effective ways for individuals, families and businesses to move their belongings.

These guidelines are adaptable to adult education, college-level courses and teacher training, as well as for high school driver education programs. They may be used as suggestions for state (provincial) departments of education, colleges and universities, local school systems and other organizations which share the leadership responsibility for traffic safety education.

Acknowledgments

We are deeply indebted to the following individuals and organizations for their efforts in developing and updating this program.

Allen Robinson, Ph.D.
ADTSEA CEO
Indiana, Pennsylvania

Paul G. Specht, Ph.D. CSP
Millersville University
Dept. of Industry and Technology
Occupational Safety and Environmental Health Program
Millersville, Pennsylvania

James D. Fait, P.E., BSME
Director of Engineering Services
U-Haul International, Inc.
Phoenix, Arizona
Chair, SAE Trailer Committee

Developing a Trailering Program

Careful planning and coordination must occur when implementing a trailering program.

The training organization, the owner of the car and the trailer-rental company or dealer should be involved in the preliminary planning. It may be advantageous to initiate a meeting between the owner of the car and the trailer company or dealer who will be furnishing the hitch and trailer.

Also, there should be a formal written agreement between all parties involved, which establishes responsibility for maintenance, service, etc., of the car and specifies the utilization limits of the trailer.

Following the above recommendations will encourage a continuous cooperative and supportive relationship with all concerned. Good luck in your efforts to provide a quality and meaningful Safe Trailering Program.

How To Use This Guide

This guide has been structured to be a flexible teaching tool. It is understood that time restrictions may require some teachers to abbreviate their presentation of safe trailering. In such cases, the editors of this guide suggest that teachers stress at least three major points.

1. The *system concept*, its significance and components
2. The importance of *proper loading*, particularly loading the trailer heavier in front
3. Adoption of a *compensatory attitude*, particularly the necessity to slow down

Actual behind-the-wheel trailering experience is strongly encouraged. Details concerning a free loan trailer program provided by the U-Haul Rental System and questions about the Safe Trailering Program should be directed to:

Director, Education Services
U-Haul International, Inc.
P.O. Box 21502
Phoenix, Arizona 85036
Dir_edservices@uhaul.com

Introduction

Extent of Trailer Towing

Many people are surprised at the extent of trailer towing. It is so commonplace that most motorists accept trailers as a normal part of the highway scene. There are more than 16 million privately owned and small rental trailers in the United States. Trailers are towed billions of miles every year. Thus, even though trailer towing may be only an occasional practice for individuals, it is a common occurrence everyday across the nation.

The mobility, increased leisure time, popularity of do-it-yourself projects and cost-consciousness have created a need which can best be satisfied by automobiles towing trailers. Virtually all drivers and many vehicles are at some time involved in trailer towing of one form or another. For example, an SUV owner can, with the addition of a trailer, transport or tow:

- Household goods.
- Boats, snowmobiles, motorcycles, dune buggies.
- Housing trailers, camping trailers, camping supplies.
- Equipment, concrete mixers, air compressors, tillers.
- Agricultural materials, hay trailers, horse trailers.
- Miscellaneous items, junk to dump or rummage sale, trash, building materials, or literally anything.

TYPES OF TRAILERS



Systems Concept

Concept

The driver, automobile, hitch, trailer and load are interdependent elements of a total trailering system.

Objective

The student will demonstrate a knowledge of the systems concept of trailering by identifying the five components, their functions and the importance of their proper union for efficient and safe operation.

The systems concept is the best way to visualize and analyze how components function in car-trailer combinations. It provides a basis for establishing safe trailer-towing skills.

When a car tows a trailer, both the car and the trailer cease to exist as separate vehicles. They merge to form a single unit: THE CAR-TRAILER COMBINATION.

The driver, automobile, hitch, trailer and load are interdependent elements of a total system. A single-element approach is not adequate.

DRIVER	TOWING VEHICLE		CONNECTING MECHANISM				TRAILER		LOAD
Driver	Car	Frame or Structural Members	Hitch	Ball Mount	Ball	Coupler	Tongue	Body Frame Suspension	Cargo



ALL ELEMENTS OF THE SYSTEM
MUST BE COMPLEMENTARY.
THE CHAIN IS NO STRONGER
THAN THE WEAKEST LINK.

The Driver

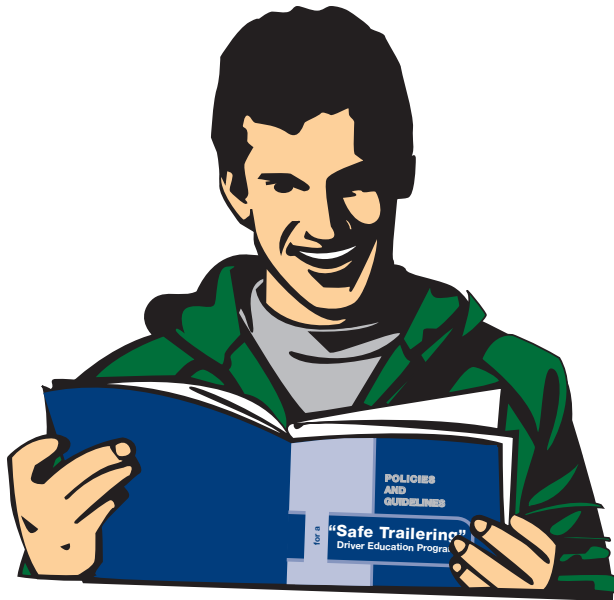

Concept

In the safe operation of a car-trailer combination, the single, most important element of the system is the *driver*.

Objective

The student will identify and select appropriate actions in all facets of driver behavior which influence the efficiency and safety of the car-trailer combination.

Most Important Element

Of the five elements of the car-trailer system, the most important is the driver. The driver is the leader, the controller, the boss of the whole system. It is the driver who determines whether or not the system will operate safely and efficiently.

Driver error is a contributing factor in a large majority of all motor vehicle crashes, while mechanical or vehicle failure is a contributing factor in only a small percentage of all such crashes. CLEARLY, THE SINGLE MOST IMPORTANT CAUSE OF CAR-TRAILER CRASHES IS DRIVER ERROR.

What kinds of driver error are involved in the operation of a car-trailer combination? Primarily the same kind as when operating a car by itself: exceeding the speed limit, driving too fast for conditions, following too closely, inattention and others that will be discussed later.

Compensatory Attitude

The single, most important thing a driver can do to assure safe and efficient car-trailer operation is to adopt a COMPENSATORY ATTITUDE. This means adjusting driving to the type of vehicle being operated. Just as a small car is not the same as a truck and a sports car is different from a full-size sedan, a car-trailer combination is not the same as the car alone. A car-trailer combination is longer, heavier, wider, higher, slower and less maneuverable. It is, however, a safe vehicle combination so long as necessary driving adjustments (compensatory actions) are made.

Operators of car-trailer combinations, with the responsibility of moving their families and household possessions safely, are motivated to adopt a compensatory attitude and adjust their driving habits to ensure their safety.

Physical Condition

As in any other driving, the physical condition of the driver of a car-trailer combination is a determining factor. Trip planning must include consideration of adequate rest prior to travel, duration of trip with planned rest stops, existing health problems and possible complications. The driver of a car-trailer combination can be subject to greater physical and mental strain than the driver of a single vehicle.

Predriving Responsibility

No discussion of the driver's role in the car-trailer system is complete if consideration is not given to predriving activities. Here, we are referring to the driver's specific responsibility for such activities as proper loading, inspection and maintenance of equipment, and recognition of local laws. The driver alone bears the responsibility for these vital activities.

The Tow Vehicle

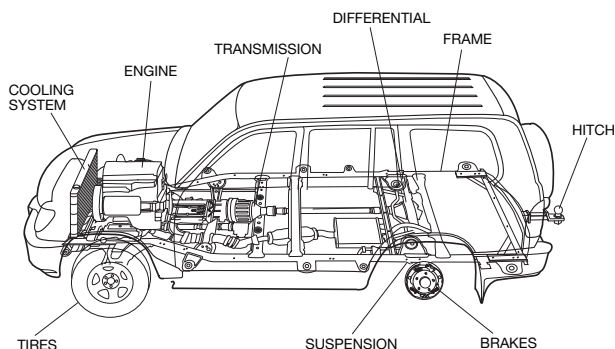

Concept

As an integral part of the system, the tow vehicle and its components have a significant influence on trailering safety.

Objective

The student will be able to briefly explain the following elements of the tow vehicle and their significance in a car-trailer combination.

- General condition
- Suspension and suspension augmentation
- Tires and tire pressure
- Braking system
- Electrical system
- Cooling system (engine, oil, and transmission cooling)
- Mirrors
- Special characteristics

General Condition

Second in order of importance in the car-trailer combination is the tow vehicle and its condition. Trailers are designed to follow the tow vehicle. Trailers will follow the erratic path of a defective vehicle just as they will follow the straight path of a nondefective vehicle. Improper tire pressure, alignment, steering adjustment or suspension will affect the driveability of the car, and thus will also affect the driveability of the car-trailer combination. Before towing a trailer, it is important that the car be in good operating condition.

Suspension and Suspension Augmentation

The tow vehicle rear springs should be of sufficient strength to support the added weight of the trailer as well as maintain the car in an approximately level position. If the rear springs are inadequate, they should be replaced. Defective shocks, springs, tires or alignment can adversely affect vehicle stability.

The normal load condition of the tow vehicle suspension can be increased by suspension augmentation devices. These devices take three major forms.

- Overload (or helper) springs
- Air bags
- Air shocks

These devices have little effect on weight distribution, so they should not be used as compensation for improper weight distribution in the car.

Overload springs can increase the vehicle spring rate and thus allow higher loads to be carried for a given spring deflection. Air shocks increase the shock height. The use of air in shocks increases stiffness and allows adjustment of the device for different loads. It should be remembered, however, that tow vehicle suspensions are often finely tuned for a smooth ride and changes in a component of the suspension can “detune” the ride and produce adverse side effects.

Trailers towed with weight-distributing hitches or equipped with certain types of sway controls can induce undesired responses in the tow vehicle. Front stabilizer bars are widely used as standard or optional equipment on vehicles and may be considered as desirable for towing large trailers with weight-distributing hitches where front wheel loads are high. They are not required for safely towing smaller trailers.

Tires and Air Pressure

Air pressure in the rear tires of some tow vehicles may be increased to accommodate the additional weight of the trailer. Inflate rear tires approximately 6 psi above normal pressure (normal is usually 30 to 35 psi) but do not exceed the pressure limit stamped on tires. Normal pressure should be maintained in the front tires. Incorrect tire pressure can cause poor stability, an uneven ride and poor gas mileage. Check pressure when tires are cold, as pressure will increase with heat when traveling. Do not bleed off (release) this increased pressure.

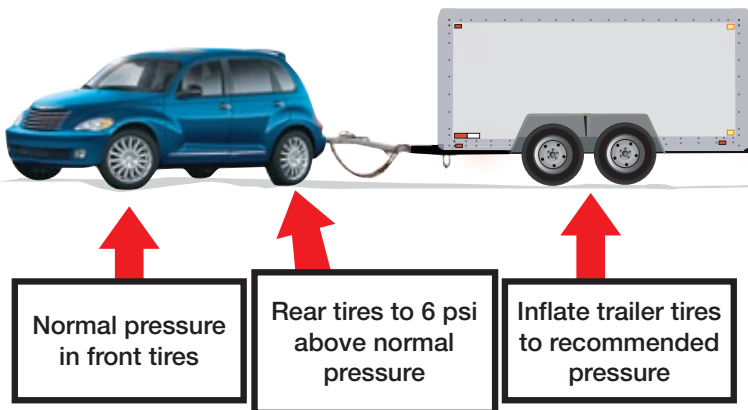

Brake System

When the trailer tongue weight is added to the rear of the tow vehicle, the tow vehicle effectively becomes “heavier” and can provide more braking traction (tire force) than the tow vehicle alone.

Most American cars are equipped with antilock braking systems (ABS) that are more than adequate to stop the vehicle safely from normal highway speeds. Consequently, by towing at reduced speeds, following at increased distance and anticipating stops with reasonable care, the increased brake load caused by a trailer of the same weight as the tow vehicle is easily accommodated.

Electrical System of the Car

Minor stress is placed on the tow vehicle’s electrical system when towing a trailer. In addition, functioning turn signals and brake lights at the rear of a car-trailer combination are necessary for courtesy and safety of drivers following a combination. The additional electrical items on the trailer could affect the car’s battery, alternator, signal lights, brake lights, etc. If the tow vehicle’s electrical system is in good condition, the trailer should have no adverse effect on the tow car. Many modern cars require special electrical adapters for trailer lights, so be sure you have the right parts installed.

Engine and Transmission Cooling

To alleviate any possible overheating of the tow vehicle, radiator cooling may be improved by flush-cleaning and refilling the radiator with new coolant. Engine oil should be fresh and of the maximum viscosity recommended for the engine and climate. Automatic transmissions may use an additional external transmission cooler for unusually difficult or extended trailer towing. Engine and transmission heat increase as automobile speed increases. Slow down to prevent overheating.

Mirrors

State (provincial) laws require that automobiles towing trailers be equipped with mirrors on both sides. Inadequate side mirrors increase driving hazard by limiting rearward vision. Adequate side mirrors increase rearward vision, but they should not be positioned to create blind spots to the front or side.

Be Familiar With Your Tow Vehicle

The operating characteristics of passenger cars differ. Persons operating cars with which they are unfamiliar, particularly sport utility vehicles (SUV) or light trucks, should familiarize themselves with the operating characteristics of these vehicles before attaching a trailer. The vehicle owner’s manual may provide information about any special trailer-towing features or handling characteristics of your vehicle.

Hitches

Concept

The point of contact between the tow vehicle and trailer is the hitch, of which there are three basic types: weight carrying, weight distributing, and fifth wheel.

Objective

The student will be able to identify the three basic types of hitches and describe their characteristics and appropriate applications.

Weight-Carrying Hitch

The weight-carrying hitch is the most commonly used hitch, accounting for about 90 percent of the passenger vehicle hitches in use today. This hitch is distinguished by the fact that it carries the entire vertical load (weight) imposed by the trailer tongue. There are two main types of weight-carrying hitches: receiver and step bumper hitches. Both of these types carry the trailer tongue weight but are distinguished by the manner in which they attach to the car.

Receiver Hitch

Receiver hitches attach to the car by permanent means, such as bolting. Their attachment points are to the automobile frame, subframe, unitized body or a combination of these points. Although these hitches are often referred to as “frame” hitches, this is a misnomer, since most automobiles produced today have no frame; instead, they feature unitized body construction, and these hitches normally attach to the unitized body panels or to a combination of these body panels and the bumper.



RECEIVER HITCH

Receiver hitches are the most common aftermarket hitch in use today. They require only one installation, and are simple to use. AS WITH ALL HITCHES MOUNTED UNDER THE CAR AND EXPOSED TO THE ELEMENTS, THESE HITCHES CAN DEVELOP RIPS, CRACKS, TEARS AND RUST THAT MAY NOT BE OBVIOUS TO THE CAR OWNER. *IT IS IMPORTANT THAT THIS TYPE OF HITCH AND ITS ATTACHMENT POINTS BE CAREFULLY INSPECTED PERIODICALLY.*



STEP BUMPER HITCH

Weight-Distributing Hitch



The second basic type hitch is the weight-distributing hitch, which is actually an accessory installed to a receiver hitch. Developed for and used primarily with passenger cars and large travel trailer combinations, this hitch does not bear all the vertical load imposed by the trailer tongue weight but tends to distribute this force from the rear of the car to the front of the car and to the rear of the trailer. This force transferral is accomplished through various systems of springs, levers, bars or chains attached to the hitch, trailer and car.

One of the effects of this weight transfer is the tendency to raise the rear of the car toward a level position; thus, weight-distributing hitches are also called “load leveling.” They are also referred to as “weight equalizing,” but these terms are not wholly accurate, as true weight equalization is overadjustment, and undesirable.

The weight-distributing hitch has the advantage of reducing that portion of an excessively heavy tongue load borne by the rear of the car and distributing parts of this load to the front of the car and to the rear of the trailer. Over-adjustment of the weight-distributing hitch can decrease the effectiveness of the tow car’s rear suspension, disturb the weight distribution of the trailer, and transmit tremendous forces through the car thus bending, warping, ripping or weakening the car’s frame, subframe or unitized body. It is very important to install and adjust the weight-distributing hitch according to instructions for the specific product in use, and the attachment points should be checked for damage periodically.

Fifth wheel hitches are usually mounted in a pickup bed and are similar in operation to those used by truckers on commercial vehicles. The fifth wheel portion of the hitch is attached to the frame of the tow vehicle through the truck bed. A gooseneck hitch is similar to a fifth wheel, but uses a ball as the connection point.

Hitch Strength Ratings

All hitches are assigned ratings by their manufacturers based on the maximum weight of the trailer which can be towed. Users must be certain that the hitch to be used has a trailer weight rating sufficient to tow the intended trailer. Most weight-distributing hitches are rated to tow heavier trailers, while most weight-carrying hitches are rated to tow medium and smaller trailers. If a car is purchased with a hitch already attached, the rating (stamped on the hitch and on the hitchball) should both be checked prior to attaching a trailer.

The Trailer

Concept

The performance of the trailer element of the car-trailer combination system is dependent upon type, speed, design and braking ability.

Objective

The student will demonstrate a knowledge of trailering by defining pertinent terms and explaining proper tongue-weight, speed and braking systems as they relate to trailers in a car-trailer combination.

History

Trailers existed thousands of years prior to the first automobile, which was itself a motorized full trailer. Before the wheel was invented, primitive man used the trailering principle to haul goods on a drag sled (travois). The ancient Egyptians and Greeks used trailers to transport their building materials, while the Romans applied this principle to war in the form of the war chariot—one of the simplest of all semitrailers.

Word Meanings

The root meaning of the word “trailer” is “to trail,” which means “to follow.” This means that a trailer plays a passive role in a vehicle combination: following the active lead vehicle. A trailer follows the speed, acceleration, deceleration and path of the lead vehicle.

There are two general categories of trailers: the full trailer and the semitrailer. A full trailer has its weight totally carried by the trailer wheels; none of its weight is carried by the towing vehicle, e.g., a covered wagon with wheels on all four corners. A semitrailer has a part of its weight carried by the trailer wheels and part carried by the towing vehicle, e.g., a chariot with the wheels in the middle. With the semitrailer, the lead vehicle—in the case of the chariot, a horse—carries part of that trailer’s weight.

The Semitrailer

Since the only trailer used today with the passenger automobile is the semitrailer, the rest of this book will be limited to consideration of the semitrailer and the word “trailer” will be taken to mean “semitrailer.”

Semitrailers in use with passenger cars today include: boat trailers, house trailers, auto transport trailers, motorcycle trailers, horse trailers, utility trailers, equipment trailers, camper trailers, mobile home trailers, sailplane trailers, farm trailers and many others.

FULL TRAILER

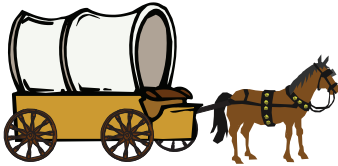
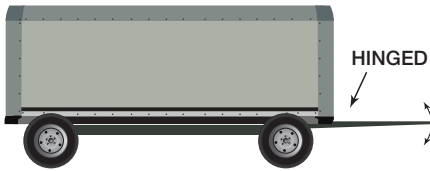

SEMITRAILER

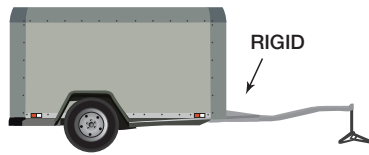

Trailer Nomenclature

- The trailer box is the main body of the trailer (sides, doors, roof) that is built on top of a trailer frame or undercarriage.
- The tongue is an extension of the trailer frame forward of the trailer box toward the car.
- The coupler is the connecting device mounted at the front of the trailer tongue that, together with the hitch ball on the car, connects the trailer to the car.
- Tongue weight is that portion of trailer weight that is transmitted through the trailer tongue and carried by the car.
- The hitch (previously illustrated) is that part of the connecting device that is attached to the car.

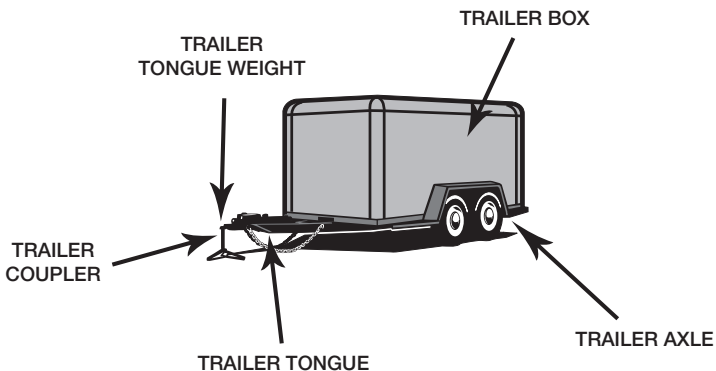

The Principle of Trailer Stability

The principle fundamental to all trailers—the principle that makes a trailer “trail”—is the engineering principle of stability. Stability is defined as the tendency for a system to stay in equilibrium, or to return to equilibrium after being displaced or disturbed. For trailers, this is called “sway stability,” and is the tendency for a trailer to stay in the direction in which it is traveling and to return (self-center) to that direction when deflected.

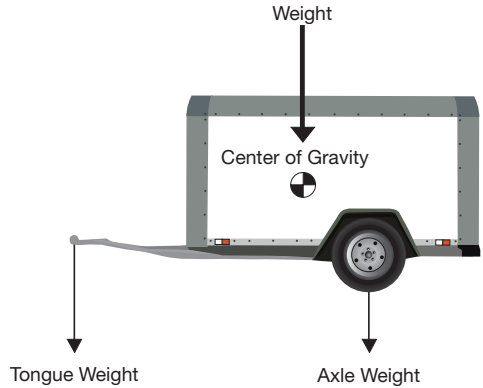

Positive stability in a trailer is achieved by proper tongue weight. In practice, this is achieved either by building the trailer heavier in front, loading the trailer heavier in front, moving the trailer wheels rearward or a combination of all three.

Positive stability in a trailer causes the trailer to tend to continue in the direction in which it is traveling, and once deflected to return to that original direction, i.e., to “trail” after the car. As the trailer weight located forward of the trailer wheels increases, the trailer tongue weight increases, as does the tendency of that trailer to follow the car, resist lateral (side to side) deflection and self-center after any deflection.

Improper Tongue Weight

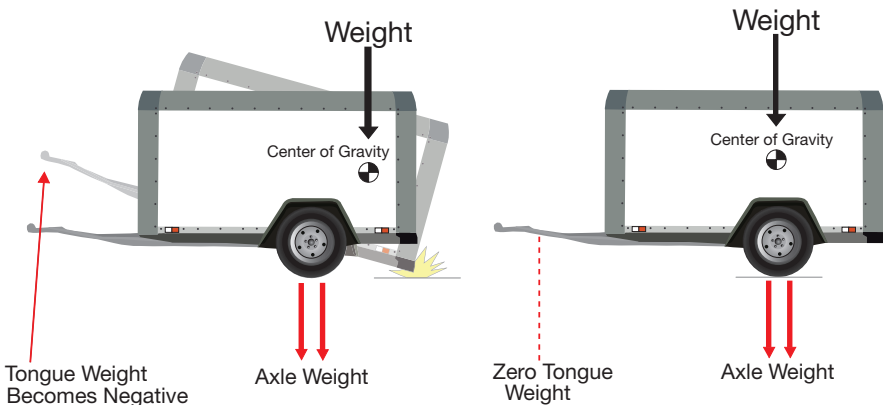

Trailers can be made to have zero or neutral stability by balancing the trailer and its load directly over the wheels. This is the zero-tongue-weight condition. This is a very dangerous practice because no stability means no resistance to lateral deflection, and no self-centering capability. The trailer will sway indefinitely until speed is reduced.

Trailers can even be made to have negative stability (instability or unstable) by loading the trailer so that it is heavy in the rear. This is the negative tongue weight condition and is an extremely dangerous practice because it tends to make the trailer turn away from the direction in which it is traveling and not to return to its original direction once deflected. Simply stated, loading a trailer heavy in the rear makes that trailer want to “swap ends.” This phenomenon is known as “**WHIPPING**” and is violent, dangerous and uncontrollable.

Whipping should not be confused with “weaving,” which is much less violent and less dangerous than whipping. Weaving is a slight wandering in the path of the car-trailer combination which can be caused by improper steering adjustment, driver inattention, high winds or uneven road surfaces. While weaving is a fairly common occurrence, whipping occurs rarely, but when it does, it is very violent and is almost always a result of failure to load the trailer heavier in front.

Ensuring Proper Tongue Weight

To ensure proper tongue weight, most trailer manufacturers construct their trailers heavier in front. Experience has shown that passenger car trailers operate best when the trailer tongue weight is between 5-15 percent of the total trailer weight. The exact loading for a particular trailer depends on the design of that trailer. This is why the manufacturer’s loading instructions always should be followed. The lesson of the stability principle is, however, certain: “Load your trailer heavier in front.”

Trailers without Brakes

A large number of smaller trailers now safely operating on the highways do not, and should not, have brakes. It is not economically feasible to equip all trailers with brake systems, the cost of which may double the initial cost of many small, lightweight models with no significant change in their safety characteristics. Brake maintenance costs can substantially increase the cost of owning a small trailer. In many cases the safety and reliability of the trailer would actually be impaired.

Most modern automobiles are equipped with brakes that are more than adequate to stop the automobile safely from highway speeds. The braking energy required to stop a vehicle of a given weight increases rapidly as the speed of that automobile increases. Simply stated, the braking energy required to stop a 3,000 pound car at 75 mph is equal to it’s:

$$\frac{\text{mass} \times \text{velocity}^2}{2} \quad \text{or}$$

$$\frac{93.2^* \times 110^{**} \times 110}{2} \quad \text{or}$$

563,860 foot pounds (210 horsepower***)

- * Mass is expressed in weight in pounds ÷ gravity (3,000 ÷ 32.2)
- ** Velocity is expressed in feet per second
- *** Horsepower is based on 4.88 seconds to stop at 0.70 G.

This same braking capacity of the car will be available even if the vehicle of 3,000 pounds is doubled to 6,000 pounds by the addition of a 3,000 pound trailer, IF THE SPEED IS REDUCED to 55 mph, or,

$$\frac{186.4 \times 80.7 \times 80.7}{2} = 606,964 \text{ foot pounds}$$

By reducing speed (to 55 mph), the 6,000 pound car-trailer combination will have almost the same braking capacity as the car alone at 75 mph.

This relationship holds true for all car-trailer combinations and yields the general rule: IF YOUR TRAILER IS NOT EQUIPPED WITH BRAKES AND WEIGHS EQUAL TO OR LESS THAN YOUR CAR, THE SPEED OF YOUR CAR-TRAILER COMBINATION SHOULD BE REDUCED BY 25 PERCENT FROM WHAT YOU WOULD NORMALLY BE DRIVING YOUR CAR AT ALONE.

This is a conservative rule for two reasons.

1. Most modern automobiles are equipped with brakes that are more than adequate to stop the automobile from highway speeds and thus have some excess braking capacity for a part of the added weight of the trailer.
2. When the trailer tongue weight is added to the rear of the automobile, plus the added force of a forward weight shift of the trailer during stops, weight is added to the rear of the automobile and the tires of the automobile gain more adhesion, enabling the automobile brakes to operate more efficiently and more nearly to capacity.

Trailers with Brakes

There are two basic types of trailer brake systems in common use today: electric or automatic hydraulic surge. Electrically operated brakes depend on the automobile electrical system for their power source. Hydraulic surge brakes are generally automatic and self-contained entirely in the trailer, and are activated automatically upon deceleration of the automobile.



HYDRAULIC SURGE BRAKE

The operating difference between good automatic electric and good automatic hydraulic surge brakes is small, and both are good braking systems for the occasional car-trailer combination operator.

Electric trailer brakes require a controller installed in your car, with wiring connections to the trailer. The controller is next to the driver and it must be adjusted to the trailer. Be sure you have the proper instructions for the controller.

A good, properly installed trailer braking system will not reduce the stopping distance of a car-trailer combination to equal that of the car alone. No braking system can change the fact that the car-trailer combination is longer, heavier, higher, wider and less maneuverable than the car alone, and a 25 percent reduction in speed and an increase in following distance is strongly advised.



EMERGENCY BREAKAWAY ACTIVATED

Trailers with brakes should have a breakaway chain connecting the trailer to a frame member of the towing vehicle or to the hitch. The breakaway chain engages the trailer's brakes if the trailer becomes disengaged from the car.

Safety Chains

All trailers should be equipped with two safety chains. One end of the chain is permanently attached to the trailer tongue while the other is connected to a frame member of the towing vehicle or to the hitch. The advantage of two safety chains is the additional safety of two chains and the fact that you can cross the chains beneath the coupler to require less slack for turning.

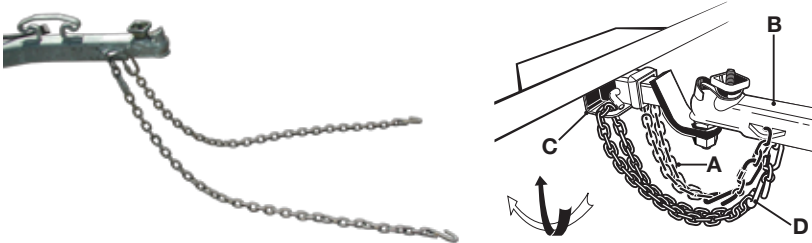

SAFETY CHAINS

Therefore, a trailer with brakes should actually have three chains for you to connect: a brake breakaway chain, and two safety chains crossed beneath the coupler.

Trailer combination stability may be discussed in greater detail here. The illustrations noted indicate the three basic forces affecting controllability and the factors affecting each force.

CONTROLLABILITY

DETERMINED BY THE RESPONSE CHARACTERISTICS ALONG
THREE PRINCIPAL AXES

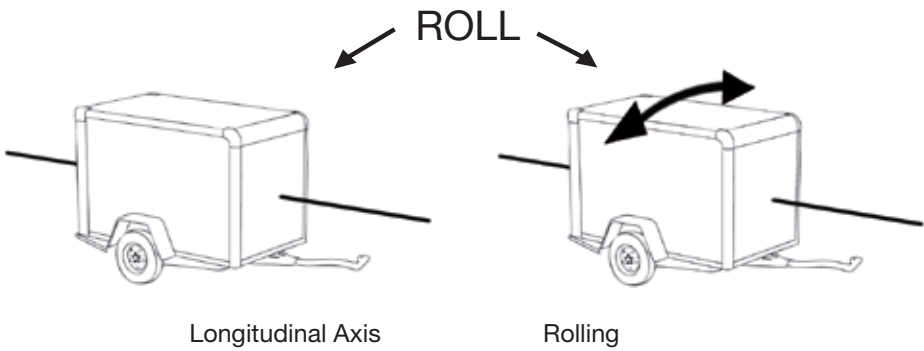
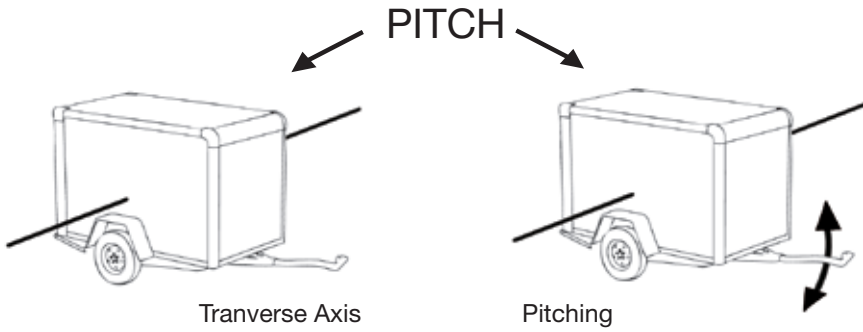
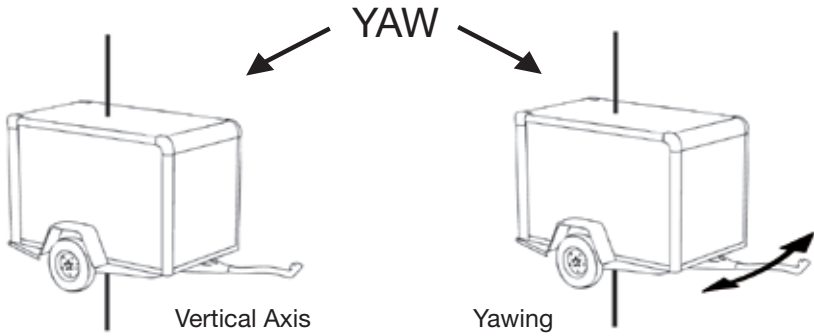

YAW CONTROLS



1. LOCATION OF TRAILER CENTER OF GRAVITY
2. TIRE CORNERING STIFFNESS
3. FORWARD SPEED
4. LOCATION OF TRAILER AXLE

PITCH CONTROLS

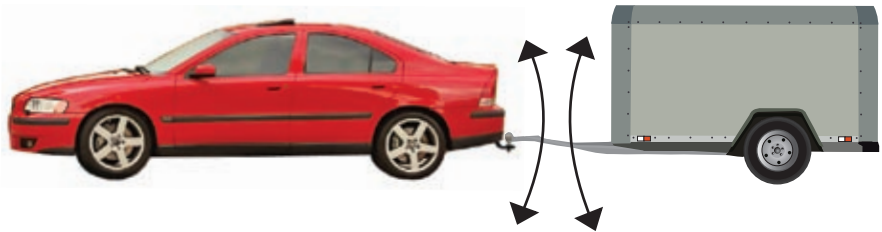

1. STIFFNESS OF AUTOMOBILE SUSPENSION
2. LOCATION OF TRAILER CENTER OF GRAVITY
3. COUPLING MECHANISM
4. HYSTERESIS FRICTION OF TRAILER SUSPENSION

ROLL CONTROLS

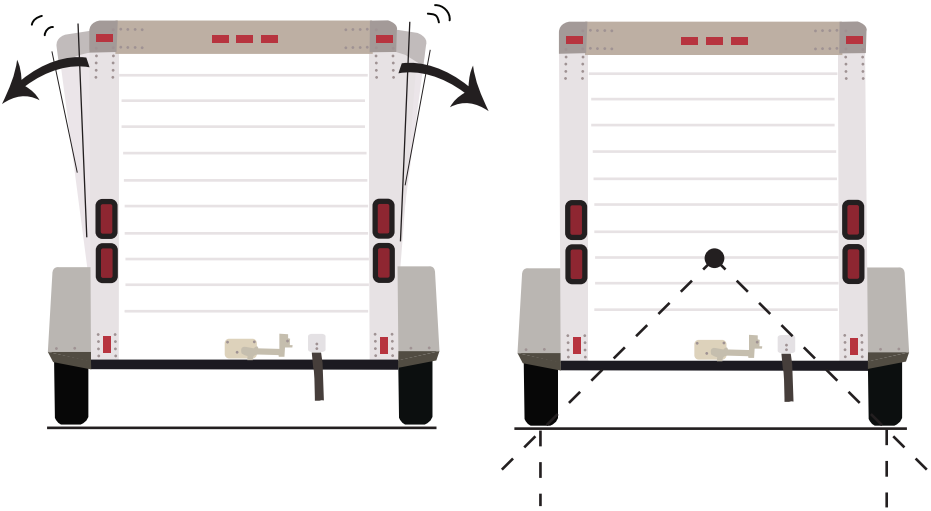

1. LOCATION OF TRAILER CENTER OF GRAVITY
2. TIRE TRACK WIDTH
3. TRAILER SUSPENSION STIFFNESS
4. TIRE CORNERING STIFFNESS

Loading

Concept

The proper distribution of weight in the trailer and tow vehicle is critical for adequate control of the combination.

Objective

The student will be able to state the principles of proper loading and how loading affects the tow vehicle, the trailer and the car-trailer combination.

Automobile Loading

Manufacturers of many SUVs and automobiles with rear seat room for three passengers recommend a total rear seat and cargo area load of 650 lbs (three 150-lb passengers plus 200 lbs cargo). As part of a car-trailer combination, trailer tongue weight is added to the rear of your car and adjustments may need to be made in order to:

1. Stay within the structural capacity of the car and hitch components.
2. Prevent excessive changes in car attitude (affecting proper headlight aim).
3. Prevent undesirable changes in car handling.

As more weight is added to the rear of an already front-heavy car, the handling characteristics start to change from basic understeer to oversteer. Oversteer is a generally undesired handling characteristic, and the change in handling characteristics can be dangerous for drivers who have not adjusted themselves to accept this difference in handling. To minimize the amount of this handling change, you should minimize the amount of weight (cargo and passengers) carried in the rear area of your car.

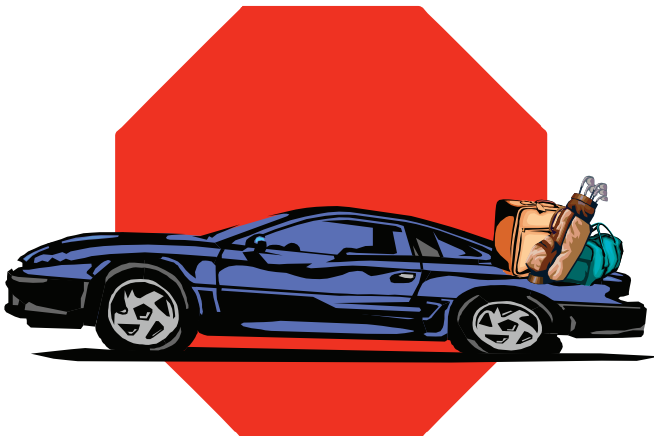

Recommended maximum passenger/cargo load is reduced by an amount equal to trailer tongue weight carried on the car hitch. This extra weight can be compensated for by decreasing the load carried inside the trunk and rear seat areas. For example, an expected trailer tongue load of 300 lbs would require a reduction in rear passenger and cargo load by 300 lbs.

Reducing this load is best accomplished by placing the lighter passengers and cargo or no passengers and cargo in the rear seat and cargo areas. If you are not sure or feel the car is handling improperly, check the car rear axle weight on a scale and make sure it does not exceed the GAWR label in the car-door opening.

If the car's rear springs are depressed so as to adversely affect handling or headlight aim, the following solutions may be helpful.

1. The load in trunk and rear seat areas should be reduced.
2. Overload rear springs could be installed.
3. Heavy-duty rear springs and shocks could be installed.

NEVER ATTEMPT TO TAKE WEIGHT OFF THE CAR BY LOADING THE TRAILER HEAVY IN THE REAR!

Trailer Loading

Trailers should be loaded more heavily in front so that approximately 5-15 percent of their total weight is carried on the tow car hitch. This is the trailer tongue weight referred to earlier. Trailers designed for and operated with a WEIGHT-CARRYING HITCH should have a tongue weight of about 10 percent of their total weight, while trailers designed for and operated with a WEIGHT-DISTRIBUTING HITCH should have a tongue weight of about 10 to 15 percent of their total weight. Because the great majority of passenger car-trailer combinations use weight-carrying hitches and because most weight-distributing hitches have specific detailed instructions for their use, this discussion will concentrate on the loading of trailers for use with weight-carrying hitches, although the same principles can be applied to trailers utilizing weight-distributing hitches.

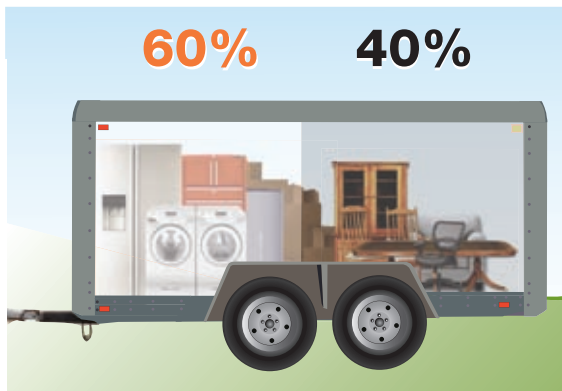

Load Heavier in Front

TRAILERS MUST BE LOADED HEAVIER IN FRONT. Load cargo so that approximately 60 percent of the trailer weight is in the front half of the trailer. Keep the center of gravity low, with heavy items (including books) on the floor of the trailer, not packed on the top of other items. Keep the center of gravity forward (approximately 10 percent of the loaded trailer weight on the tow-car hitch). The heavier the trailer and cargo, the greater the weight that must be carried on the tow car hitch. Pack all goods closely and firmly, and secure any partial loads with ropes and packings.

In spite of a common misconception, it is untrue that a trailer with two axles may be loaded evenly over the axles to eliminate the need for loading heavy in front. Dual-axle trailers react the same as single-axle trailers and must be loaded heavier in front. The only reason these trailers have two axles is to provide an additional set of wheels for increased load-carrying capacity.

If the trailer is not loaded heavier in front but is balanced over the trailer wheels or heavy in the trailer rear, the trailer will lose its stability and the towing vehicle-trailer combination will be dangerously unstable and difficult to control. FAILURE TO LOAD THE TRAILER HEAVIER IN FRONT IS A LEADING CAUSE OF CAR-TRAILER MISHAPS.

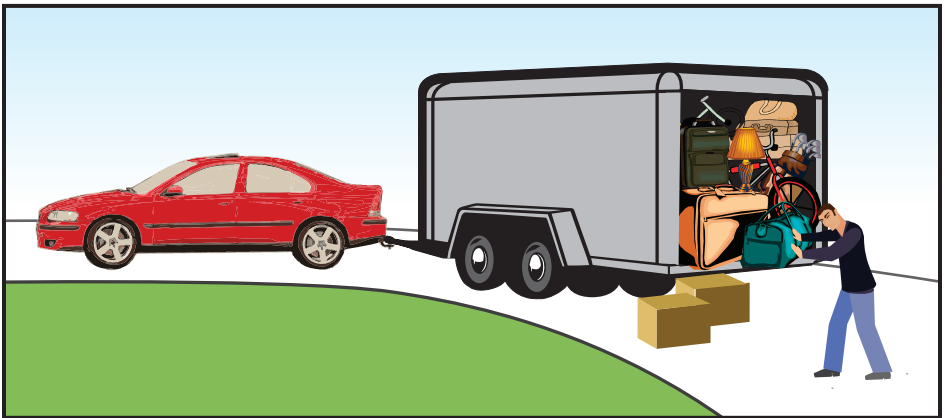

Don't Overload

Most trailers have their unladen (empty) and maximum gross (full) weight rating (GVWR) labeled on the trailer or listed in the owner's manual. Exceeding the trailer manufacturer's recommended maximum gross weight can lead to damage or failure of the trailer's component parts. The weight of various cargoes may be approximated by allowing the following weights for every cubic foot of trailer space utilized.

- Household goods (furniture, clothes)—5 to 7 lbs/cu. ft.
- Commercial goods (wood, foodstuffs, appliances)—25 lbs/cu. ft.
- Sand, gravel, rocks—100 lbs/cu. ft.

If in doubt, the weight may be checked on a commercial or state (provincial) scale, as listed in the Yellow Pages under “Scales Public.”

Weight Ratios

When towing a trailer not equipped with brakes, the loaded weight of the trailer should not exceed the unloaded weight of the tow vehicle. When towing a trailer equipped with brakes, the trailer weight may exceed the car’s weight, depending upon the trailer design and the trailer manufacturer’s recommendations. Excessive trailer weight can lead to stress on the automobile.

To determine the empty weight of a particular car, check the owner’s manual, registration papers or new-car dealer. Examples of approximate unloaded weights are:

2008 Honda Accord	3,600 lbs.
2008 F150 Pickup	4,700 lbs.
2008 Chevy Tahoe	5,300 lbs.

Contraband

It is against the law to carry passengers in the back of any trailer. Passengers in the trailer risk injury due to shifting cargo, asphyxiation and lack of collision protection.

Flammables such as gasoline or paint thinner should not be transported. An empty or partially full container is just as dangerous as a full one. Flammables may explode or ignite because of vehicle movement, road vibrations or cargo shifting.

Open Trailers

When loading open trailers, care should be taken to restrict the cargo to the space within the trailer dimensions. When this cannot be accomplished, trip planning can prevent mishaps involving low underpasses, tight thoroughfares, etc. And remember that discarding lighted cigarettes from a car may not only cause fire damage to grass and woodlands, but the wind can carry the cigarette into your open trailer, where fire damage can occur. Be sure the load is secured so that it will not shift in the trailer and cause a stability problem. Unsecured cargo may be ejected from the trailer and create a roadway hazard.

Operation of the Car-Trailer Combination

Concept

Proper operation of the car-trailer combination depends on the knowledge, skill and attitude of the driver.

Objective

The student will state or demonstrate the skills and techniques necessary for the safe operation of car-trailer combinations.

Compensatory Attitude

Safe trailering simply involves adopting a good compensatory attitude. Even the most experienced drivers in the world will compensate for the peculiarities of the automobile they happen to be driving. Trailering is no different. No matter how much experience people have, they cannot change the vehicle they are operating to fit their driving habits, but must change their driving to fit the vehicle.

The driver must recognize that they are no longer driving a car, but operating a different vehicle, a car-trailer combination. They must compensate for performance differences of this new vehicle by modifying driving techniques. The mind must be adjusted to accept a slower pace of travel. By approaching the driving task with plenty of rest, avoiding extended periods of driving particularly at night and allowing adequate following distance, drivers will improve their trailering performance. The following driving techniques and good common sense judgment will increase your confidence and help you enjoy safe, convenient trailering.

Connecting and Disconnecting the System

The car-trailer combination must be securely connected via the hitch and coupler, with safety chains and breakaway chain (on trailers with brakes) properly attached. A good general rule is: When you begin trailer hookup, always finish the process without pausing or stopping to do something else. Otherwise, you may forget to complete the connection properly.

Ball and coupler combinations vary, but all should be tight, and checked periodically to maintain tightness. Hitch balls vary in size (1-7/8", 2" or 2-5/16") and should be mated to the same size coupler or to a coupler that fits multiple sizes. Safety chains—permanently attached to the trailer tongue—should be crossed beneath the coupler and connected to the hitch or to a *frame member* of the tow vehicle. Allow enough slack for turns but make sure the chains do not drag on the ground.

The breakaway chain will activate trailer brakes if disengagement of the trailer from the hitch or car occurs. This chain also should be hooked to a *frame member* or the hitch. Use slightly less slack than the safety chains.

Electrical connections should be made according to instructions so that trailer brake lights, turn indicators and other lights function properly.

Regardless of the elements of your car-trailer combination, make a step-by-step checklist to follow in properly connecting the system. This checklist can be followed—in reverse order—to disconnect the system.

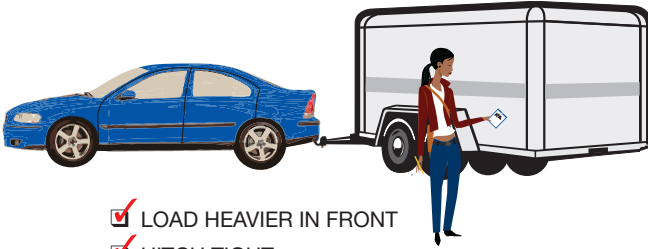

- LOAD HEAVIER IN FRONT
- HITCH TIGHT
- CHAINS ATTACHED
- LIGHTS WORKING
- TIRE PRESSURES OK
- REDUCE SPEED
- THINK AHEAD
- STOP OFTEN FOR REST
- INSPECT OFTEN
- LOAD SECURE
- WEAR YOUR SEATBELT

Vehicle Inspection

Before starting and at each fuel stop, the driver should walk around the car and trailer, stopping to check hitch and coupler tightness, safety chains attachment, lights and tire pressures. Can you see out the side view mirrors? Do the brakes operate properly? If while driving any unusual noise is heard or trouble is suspected, the car-trailer should be stopped at a safe place completely off the roadway and the problem identified and corrected.



Reduce Speed

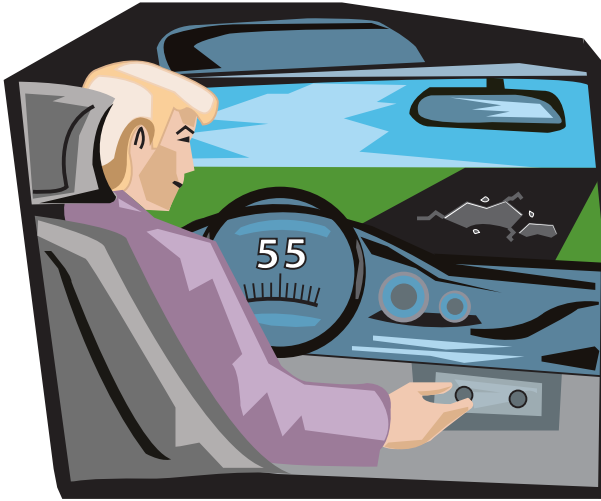

As we learned earlier, the addition of a loaded trailer to a passenger car requires an approximate 25 percent reduction in speed of the car-trailer combination.

All vehicles have a speed beyond which it is unreasonable to expect adequate emergency control, and for most passenger car-trailer combinations this speed can be conservatively set at 55 mph. **THE MAXIMUM RECOMMENDED SPEED FOR MOST CAR-TRAILER COMBINATIONS IS 55 MPH.** As driving conditions deteriorate, you must further reduce this recommended maximum speed.

Do not be lulled into a false sense of security because your trailer tows easily at higher speeds. An emergency road hazard that would be avoidable at 55 mph might become unavoidable at 60 mph. The posted speed limit is usually the same for trucks and car-trailer combinations. Observe these speed limits especially if they are less than 55 mph. Excess speed is one of the most important causes of car-trailer crashes.

Driving 55 mph is also good for the environment. Driving 55 mph increases fuel efficiency and reduces CO₂ emissions. For every 10 miles above 55 mph, fuel efficiency is reduced by approximately 3-5 miles per gallon and CO₂ emissions are increased by approximately 15 percent.

Stopping

A car-trailer combination is heavier than a car alone and requires more distance to stop. Allow about 325 feet between yourself and the vehicle ahead when driving at 55 mph. This is the same as two seconds for the car plus two seconds for the trailer, for a total of four seconds for the combination. When driving in adverse conditions such as rain, snow or fog, use at least a five-second gap.

Failure to follow this rule-of-thumb can result in unnecessary and frequent use of your brakes, and prolonged use of brakes can result in overheating and loss of braking effectiveness.

Hills

When going up hills, shift to lower gears so that the motor is not lugging and can turn over easily. When going downhill, reduce speed and shift into lower gears before starting down. A good rule of thumb is to go down the hill in the same gear you had to use to go up the hill. Vehicle stability decreases when going downhill. Allow for this by decreasing speed. Do not increase speed. Slow down before you go down.

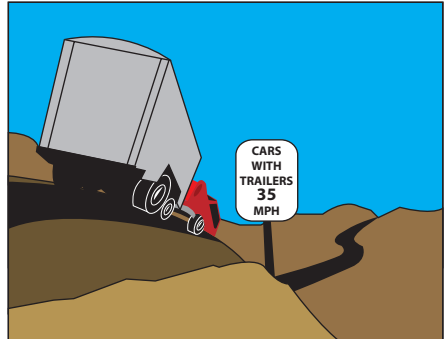

Passing

Your car-trailer combination is longer and heavier than your car alone, requiring more time and distance to pass. Have plenty of clear highway ahead. Never pass on hills or curves. Passing or being passed by another vehicle can create air suction that tends to move both vehicles sideways. This danger increases when the speed differential is great, when there are strong crosswinds or when one vehicle is very large (such as a commercial tractor trailer rig). If traffic is backed up behind you—going uphill, for instance—pull off the road at a safe place and let other vehicles pass. Be sure there is sufficient space at such a turnoff so that you can return to the road without having to back up.

Crosswinds

Large trailer side areas increase the effect of crosswinds on your vehicle combination. Side winds tend to move the vehicle combination sideways and are particularly dangerous in hilly areas where the vehicles are alternately shielded from and then exposed to wind. Steer straight and reduce speed to decrease the disturbing effects of the wind.

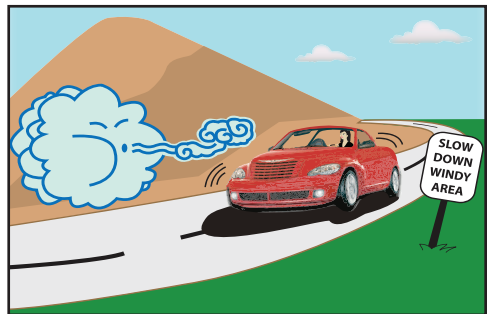

Turns and Corners

When making turns while towing a trailer, some adjustments must be made because the trailer does not follow directly behind the car. The trailer will turn in a shorter arc (turning radius) than the tow vehicle does and, not being aware of this, some people will make a right-hand turn, for instance, and find that the trailer will go up over the curb, possibly striking a traffic sign post or endangering a pedestrian.

When making a right turn, the car should be kept near the left edge of your lane, but not over the line. Proceed slightly past the curb line with the front of the car, and then turn sharply into the right-hand lane. The trailer will be cutting a shorter arc, but will not go over the curb if you execute the turn properly.

When making a left turn, stay near the right-hand side of your lane, but not over the line. Proceed well into the intersection and turn smoothly into the inside lane. Again, the trailer will cut a shorter arc, but will not strike cars stopped at the intersection if you turn properly.

Never Operate an Unstable Car-Trailer Combination

Instability (swaying or whipping) of a car-trailer combination at low speeds usually increases at higher speeds. Steer straight and reduce speed immediately but gradually; do not apply the brakes. Never increase speed. If you increase speed, the combination will not “straighten itself out” but will continue its instability, only with increased speed and violence. Stop at the first safe opportunity completely off the highway.

Check to be sure that the trailer is loaded heavy in front and according to the trailer manufacturer’s recommendations. Reload if necessary. Next, make certain that the car trunk area is not overloaded with cargo. Then check the automobile suspension alignment. Next, look for low tire pressures on both the car and trailer. Finally, be sure that you were not traveling at an excessive speed.

Vehicles equipped with independently operable electric trailer brakes (controlled by a lever or switch near the driver) can be stopped from whipping by applying only the trailer’s electric brakes. Once the whipping has stopped, apply the car’s brakes to stop the combination. NEVER proceed without first correcting the problem which caused the whipping. Use of the trailer’s electric brakes independently of the car’s brakes is an emergency measure only.

Let’s Back Up

Always try to get an observer to help you back up. They can motion to direct you as well as watch for children or obstacles.

Try this easy method to help control direction while backing up a trailer. Back slowly and look directly over your shoulder through the rear window (without using your mirrors). Keep your hand at the bottom of the steering wheel. To move the trailer left, move your hand to the left. To back to the right, move your hand to the right. If the trailer starts to jackknife - STOP - and pull ahead to straighten out; then begin again. Once you start to go correctly, just follow the trailer around.

Conserve Gasoline

Your tow car will naturally consume more gas when towing a trailer. Better gas mileage is obtained by keeping a steady speed at about 55 mph. Speeds over 55 mph can use 25 percent more gas.

Pro Driving Tips

A disproportionate number of all vehicle crashes occur at night—with a tired driver—exceeding the recommended speed—on a downgrade, wet road or curve.

- Don't attempt to drive “straight through.” Be rested.
- Slow down for downgrades, wet roads or curves.
- Teenage night drivers have two times the fatality rate as day drivers, so avoid driving at night.



**DON'T
FORGET!**



Don't forget to CHECK your LIST

Appendix

On-Site Safe Trailering Course

On-Site Safe Trailering Course Outline

TITLE	CONCEPT	OBJECTIVE
<i>SYSTEMS CONCEPT</i>	The driver, automobile, hitch and trailer are interdependent elements of a total trailering system.	The student will demonstrate a knowledge of the systems concept of trailering by identifying the five components, their functions, and the importance their proper union for efficient operation.
<i>THE DRIVER</i>	In the safe operation of a car-trailer combination, the single, most important element of the system is the driver.	The student will identify and select actions in all facets of driver behavior which influence the efficiency of the car-trailer combination.
<i>THE TOW VEHICLE</i>	As an integral part of the system, the tow vehicle and its components have a significant influence on trailering safety.	The student will be able to explain the elements of the tow vehicle and their significance in a car-trailer combination.
<i>HITCHES</i>	The point of contact between the tow vehicle and trailer is the hitch, of which there are three basic types: weight-carrying, weight-distributing, and fifth wheel.	The student will be able to identify the three basic types of hitches and describe their characteristics and appropriate applications.
<i>THE TRAILER</i>	The effectiveness of the trailer element of the car-trailer system is dependent upon type, speed, design and braking ability.	The student will demonstrate a knowledge of trailering by defining pertinent terms and explaining proper tongue-weight, speed, and braking systems as they relate to trailers in a car-trailer combination.
<i>LOADING</i>	The proper distribution of weight in the trailer and tow vehicle is critical for adequate control of the combination.	The student will be able to state the principles of proper loading and how loading affects the tow vehicle and the trailer and the car trailer combination.
<i>OPERATION OF THE CAR-TRAILER COMBINATION</i>	Proper operation of the car-trailer combination is dependent on the knowledge, skill and attitude of the driver.	The student will state and/or demonstrate the special skills, techniques, considerations and compensations necessary for operation of car-trailer combinations.
<i>LABORATORY INSTRUCTION</i>	Actual experience provides the opportunity to demonstrate classroom principles	The student will learn basic maneuvers through drills, and, at a range or off-road location, put their knowledge into practical application. Emphasis will be to provide a diversity of situations, including high density or urban driving, passing, freeway driving and traversing hills.
<i>STUDENT GUIDE</i>	Student can follow the trailering instruction with a brief course outline and summation of the major safety factors involved in safe trailering.	Maintain interest and provide a key-points handout.

On-Site Laboratory Instruction

The teaching process for the beginning car-trailer combination driver must start with basic maneuvers. It is suggested that a range area or off-road area be utilized to set up drills to complement the following teaching sequence.

1. Inspection
 - a. Car-trailer hookup—hitch properly attached and secure, coupler tight and safety chains properly attached, all according to instructions
 - b. Lights hooked up and operating properly
 - c. Tires—in good condition and properly inflated. Be sure to check tires on both the trailer and the tow vehicle.
 - d. Load—car and trailer both loaded properly
2. Starting and Stopping
 - a. Starting
 - Consider load weight and traction.
 - Check for proper tracking of trailer.
 - Check for trailer stability.
 - Check for noises including a possible malfunction.
 - Test trailer brakes for proper operation (if applicable).
 - b. Stopping
 - Use normal stopping procedures.
 - Increased weight of the combination means increased stopping distance.
 - Hard braking at high speed or prolonged braking at any speed will result in overheated brakes and loss of braking efficiency.
3. Turns
 - a. Follow normal turning procedures.
 - b. Road surface, speed and tire condition affect car and trailer traction, and stability.
 - c. Turn wide enough to allow for the trailer tracking inside the turning arc of the tow vehicle.
4. Backing
 - a. Always clear the intended backing area by walking around the car-trailer combination for a visual check, or have another person stationed to the rear of the vehicle to observe while maneuvering.

b. Backing into a designated space:

- Hand at the bottom of the steering wheel
- Always turn and look back in the direction you are turning.
- Always move very slowly.
- Move the bottom of steering wheel in the direction you want the trailer to go
- If the trailer starts to jackknife (turn too sharply), stop, pull straight ahead to straighten out and start again.
- As proper direction of movement is achieved, gradually reverse the direction of the steering wheel until the car is following the movement of the trailer.

The student should be given as much car-trailer combination driving experience as possible with emphasis on the following activities:

1. Urban driving

2. Passing

- a. Have plenty of clear highway ahead (additional space is required to compensate for increased length of car-trailer combination)
- b. Acceleration will be reduced due to the additional weight of the combination
- c. Anticipate some effect of air suction created by two vehicles passing. (The effect increases with speed differential and/or increased crosswind velocity.)

3. Freeway driving

4. Driving over hills



